

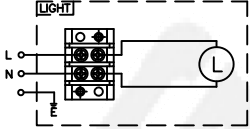

CAPACITY	SYMBOL/ SERIAL NO.	CIRCUIT DIAGRAM
AC100~240V, 50/60Hz		
10W		

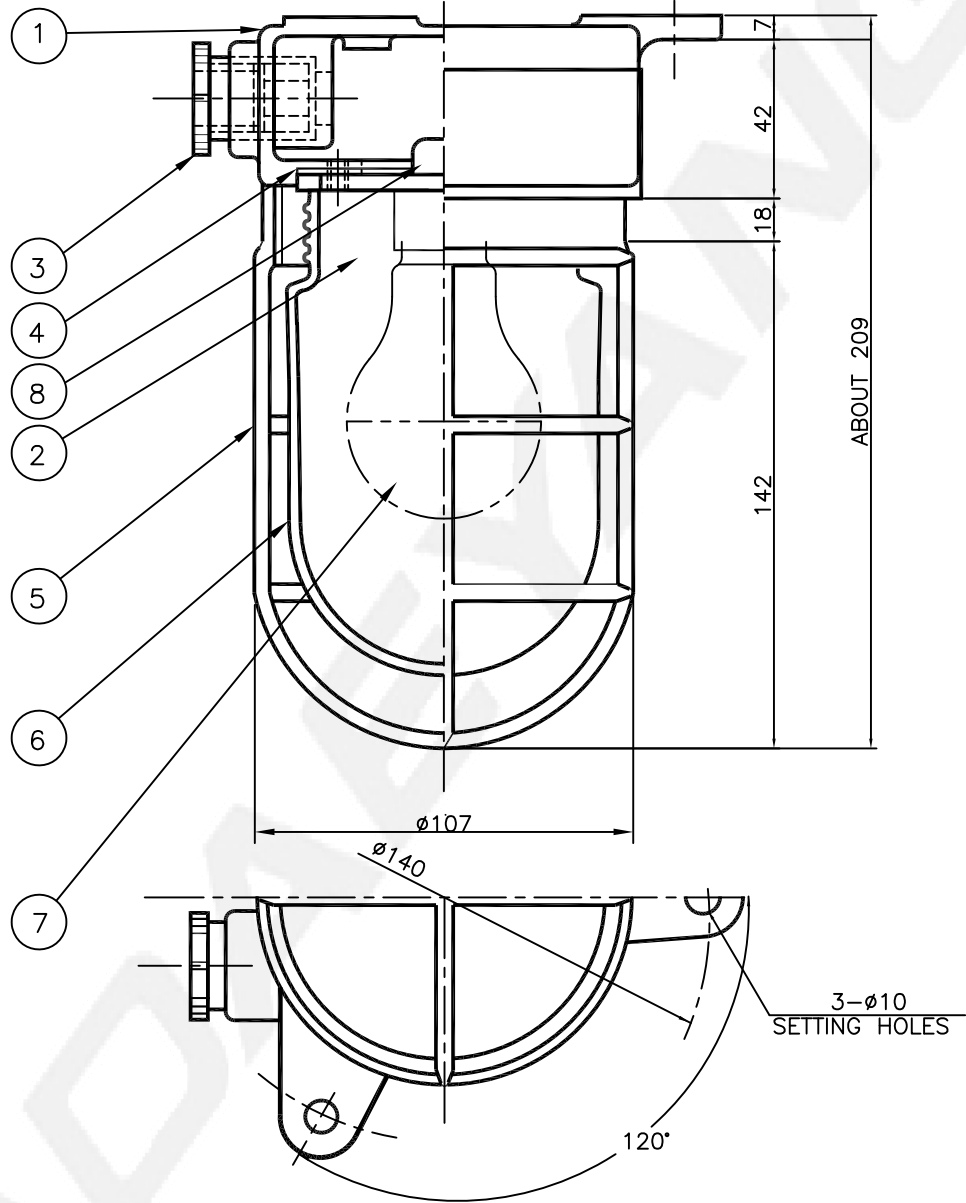

8	TERMINAL BLOCK	PHENOL	1	2P	4	GLOBE GASKET	SILICONE	1	
7	LED LAMP	-	1	3,000K	3	CABLE GLAND(#20)	BRASS	2	φ12~φ15
6	GLOBE	GLASS	1	S-90	2	LAMP HOLDER	PORCELAIN	1	E27
5	GUARD	BRASS	1		1	BODY	BRASS	1	
NO	NAME OF PARTS	MATERIAL	Q'TY	REMARKS	NO	NAME OF PARTS	MATERIAL	Q'TY	REMARKS

APPROVED	J. W. PARK	UNIT	MM	TITLE; LED PENDANT LIGHT FOR MARINE USE			
CHECKED	S. M. SON	SCALE	N/S				
DRAWING	B. K. HWANG	COLOR	NATURAL				
DATE	2021.09.05	IP	56				
				MODEL NO.	LP10-55BNCGC30	WEIGHT	2.1 Kg
				DWG NO.	LP1100207	SHEET NO.	10